



RNRG Hybrid XT Anemometer User's Manual

Author:
RNRG Technical Services



Specifications are subject to change without notice.

© Renewable NRG Systems
110 Riggs Road
Hinesburg VT 05461
Tel: 802-482-2255
Fax: 802-482-2272
e-mail: sales@rnrgsystems.com

Contents

HybridXT Anemometer	Error! Bookmark not defined.
Customer Support.....	4
Introduction	5
Using This Manual.....	5
Anemometer Operation and Considerations.....	6
Output Circuit Operation	6
Heater Operation.....	6
ESD and Circuit Protection	7
Cable Shield Decision - Important	7
Magnet Safety	7
Transport and Handling	7
Cables compatibility tables.....	8
Hybrid Turbine Control Sensor Cables	8
HybridXT Turbine Control Sensor Cable Compatibility	8
Installation and Technical Drawings.....	9
Mounting Mast Orientation	9
Prepare Shield.....	9
Mount Connector	10
Connect Cable to Controller	12
Mount Sensor.....	12
Technical Drawing	13
Grounding and Bonding Hybrid XT™ sensors for over-voltage protection.....	14
Recommended Practices.....	14
Sensor Construction Notes.....	15
Warranty & Repair	16
Declaration of conformity	18
Appendix A: FG# 4718 – Hybrid Turbine Control Anemometer.....	19
Output Circuit Operation	19
Appendix B: FG# 5763 – 4-20 mA, 50 m/s Anemometer.....	19
Output Circuit Operation	19
Appendix C: FG# 7901 – Push-Pull Anemometer.....	20
Output Circuit Operation	20
Appendix D: FG# 9365 – 4-20mA, 60 m/s Anemometer	20
Output Circuit Operation	20

Customer Support

Renewable NRG Systems offers a variety of support options to help you get the most from your Renewable NRG Systems product. If you have questions about your Renewable NRG Systems product, first look in the printed product documentation, the Knowledge Base and the Technical Forum contained in the Tech Support section of the Renewable NRG Systems web site. If you cannot find the answer, contact your salesperson or Renewable NRG Systems Technical Support for assistance using the information below. Customer support is available 8:30 AM to 5:00 PM EST, Monday through Friday.

Renewable NRG Systems Telephone: 802-482-2255
110 Riggs Road FAX: 802-482-2272
Hinesburg, Vermont
05461 U.S.A. Email: support@rnrgsystems.com

When you call or email, you should have the appropriate product documentation at hand and be prepared to give the following information:

- Customer name
- Who purchased equipment
- Item number or description
- Serial number
- When equipment was purchased
- Where equipment is installed - terrain conditions
- Description of the problem with some detail
- What events took place leading up to the problem
- What you have tried while attempting to solve the problem

Renewable NRG Systems maintains an extensive website which includes an in-depth customer support area for Renewable NRG Systems customers. If you need assistance at times other than our regular business hours, we suggest visiting our website, **www.rnrgsystems.com**.

All instruments, sensors, software and towers manufactured by Renewable NRG Systems are designed to be reliable and easy to use. We welcome your comments and appreciate your help in making Renewable NRG Systems products the best available.

Introduction

The Renewable NRG Systems Hybrid XT anemometer is an electrically heated wind speed sensor designed for wind turbine control and wind resource assessment. The sensor is mounted to the turbine nacelle or meteorological mast and provides an electrical output signal with frequency proportional to wind speed. Although the Hybrid XT sensors can be used for meteorological work, this manual is specific to turbine control applications. However, there should be little difficulty in adapting these sensors for meteorological applications.

The Hybrid XT is rugged enough to accurately measure wind speed in excess of 70m/s (156 mph), yet its relatively low moment of inertia permits it to respond rapidly to gusts and lulls. It is built with corrosion resistant materials and finishes, and is sealed against wind-driven rain and dust.

The Hybrid XT sensor line has a captive mounting system with integral connector that allows quick and easy changing of the sensor. There are only three internal components (electronics module, heater assembly and bearing assembly) for ease of maintenance. The Hybrid XT also has a spare label pocket for a customer-supplied identification label.

Using This Manual

Read this manual completely before installing and operating the Hybrid XT anemometer. Follow all instructions and recommendations closely.

This document and the sensor may use the following symbols:



Earth (Ground)



Chassis Ground



AC Voltage



AC or DC Voltage



DC Voltage



Hot Surface



This typeface within the body of the manual is used for general descriptions and instructions to the user.

This typeface is used to warn users of a potential danger, either to themselves or to the sensor.

Anemometer Operation and Considerations

Output Circuit Operation

The Hybrid XT anemometer is available with a variety of output signal types including variable frequency and 4-20mA, among others. **Details for each output type may be found in the appendices of this manual.**

Heater Operation

The heat source for the Hybrid XT is a self-regulating, constant-temperature heater. Constant heating prevents condensation and corrosion and maintains proper bearing temperature for consistent performance and transfer function. In severe wind and icing conditions, the Hybrid XT draws more power to help remain clear of ice. As conditions improve, the Hybrid XT draws less power. The Hybrid XT's self-regulating feature increases reliability, insuring that the head does not reach excessive temperatures. Excessive temperatures can stress bearing lubricants, wiring, and present a hazard in the presence of combustible materials. The Hybrid XT's heater is powered by 24 volt power, AC or DC, making it compatible with a wide range of turbine controller power supplies and remote site equipment. An optional 120 / 240 V to 24 V AC transformer is also available.

- Following a brief inrush current, after approximately 30 seconds, the heater settles into its temperature controlled mode.
- It is recommended that a 15 A slow-blow fuse be placed in-line with the heater.

NOTICE

Always power the heater on your Hybrid XT sensor! Failure to maintain constant heating may lead to corrosion or inferior sensor performance. Constant heating prevents condensation from forming on the bearings, enabling the sensor to achieve a 10 year service cycle. **If the sensor is used without the heater, the warranty will be void.**

WARNING

Sensor surfaces (particularly the head and the upper body) can become quite hot and may burn you; especially in warm ambient conditions. **Use caution when the heater power is on.**

ESD and Circuit Protection

The Hybrid XT sensor has been designed to withstand most common wiring errors and electrostatic discharge. These include reversed polarity on the power supply inputs, applying power to or shorting the signal output lines, and electrostatic discharge on any line.

However, the sensor is not indestructible. Avoid applying more than the rated power supply to any pin. While extremely rugged, nearby or direct lightning strikes may damage the sensor.

Cable Shield Decision - Important

The user must decide how to connect the shield of the signal cabling for their application. This is an important part of the overall design of the lightning protection and grounding system for each turbine design. Reference information can be found in Appendix A.

We recommend that the shield always be connected at the controller end of the cable. This provides shielding against capacitively (electrostatically) coupled interference to the sensor signal.

If the shield can be connected to ground at the sensor boom as well, the shield can also provide protection against inductive (magnetically) coupled noise sources, such as generator noise and lightning electromagnetic pulses. However, you should connect the shield at both ends ONLY if the turbine grounding system provides sufficient bonding and grounding to prevent ground loop currents in the shield wire.

On the Renewable NRG Systems -cable assembly for the Hybrid XT Turbine Control Sensor, the shield is available for connection at both ends. If the sensor end is not to be connected, cut off the shield wire at the sensor end before installation to prevent accidental contact to the sensor mount.

Magnet Safety

The Hybrid XT sensors, particularly the vane version, contain small, but powerful neodymium iron boron magnets. These magnets are strong enough to magnetize tools, erase magnetic media (floppy disks and credit cards), damage CRT's (computer monitors and TV's), pinch fingers, etc. They can also shatter if allowed to snap together, causing eye damage. If they are ingested, they can cause serious injury, or even death.



Do not allow unskilled persons to disassemble these sensors. Do not remove the magnets from their respective assemblies (Head Assembly and Shaft Assembly). Keep small magnets and small pieces containing magnets away from young children who might mistakenly or intentionally swallow them. Seek immediate medical attention if you suspect a child may have swallowed a magnet.

Transport and Handling

This sensor is a precision instrument. Please use care in its handling to protect the bearings and shaft. It is recommended that the sensor be carefully placed on its side instead of standing up.

If the sensor should tip over onto a hard surface, bearing or shaft damage may occur. Use care!

Cables compatibility tables

There have been several different versions of the Hybrid cable assembly since inception to accommodate various sensor and turbine configurations. Please see the tables below to verify cable compatibility.

Hybrid Turbine Control Sensor Cables

Item Number	Description	Notes
4716	Assembly-Cable,600V, 10m, Connector, Power, Signal, WithMountingBolt, Hybrid TCS	10 m length, 5 pin cable, Green Tag
4717	Assembly-Cable,600V,20m, Connector,Power,Signal, WithMountingBolt,Hybrid TCS	20 m length, 5 pin cable, Green Tag
8797	Assembly-Cable,600V,12m,6 Pin Connector,Power,Signal, WithMountingBolt,Hybrid TCS	12 m length, 6 pin cable, Red Tag
9234	Assembly-Cable,300V,10m, Connector,Power,Signal,WithMountingBolt,Hybrid TCS	10 m length, 6-pin cable Orange Tag
9319	Assembly-Cable,300V,20m, Connector,Power,Signal,WithMountingBolt,Hybrid TCS	20 m length, 6-pin cable Chartreuse Tag

HybridXT Turbine Control Sensor Cable Compatibility

4715	Hybrid XT Turbine Control Sensor, Vane	4716, 4717, 8797, 9234, 9319	Any cable may be used; if present, Yellow (Out 2) is not used and may be left disconnected
4718	Hybrid XT Turbine Control Sensor, Anemometer	4716, 4717, 8797, 9234, 9319	Any cable may be used; if present, Yellow (Out 2) is not used and may be left disconnected
6624	Sensor-Hybrid XT Turbine Control Sensor, Anemometer (calibrated)	4716, 4717, 8797, 9234, 9319	Any cable may be used; if present, Yellow (Out 2) is not used and may be left disconnected
5762	Hybrid XT 4-20mA Output Turbine Control Sensor, Vane	4716, 4717, 8797, 9234, 9319	Any cable may be used; if present, Yellow (Out 2) is not used and may be left disconnected
5763	Hybrid XT 4-20mA Output Turbine Control Sensor, Anemometer	4716, 4717, 8797, 9234, 9319	Any cable may be used; if present, Yellow (Out 2) is not used and may be left disconnected
7894	Hybrid XT Push-Pull Output Turbine Control Sensor, Vane	8797, 9234, 9319 (Red, Orange or Chartreuse tag) only	All six wires are required to provide both Vane signals.
7901	Hybrid XT Push-Pull Output Turbine Control Sensor, Anem	4716, 4717, 8797, 9234, 9319	Any cable may be used; if present, Yellow (Out 2) is not used and may be left disconnected
8115	Hybrid XT Coil Compatible Output Turbine Control Sensor, Anem	4716, 4717, 8797, 9234, 9319	Future Product. 8797 may be used, Yellow (Out 2) is not used and may be left disconnected
9362	Hybrid XT Vane, 4-20mA Output, Counter Clockwise	4716, 4717, 8797, 9234, 9319	Any cable may be used; if present, Yellow (Out 2) is not used and may be left disconnected
9363	Hybrid XT Vane,Push-Pull, Active High	8797, 9234, 9319 (Red, Orange or Chartreuse tag) only	All six wires are required to provide both Vane signals.
9365	Hybrid XT Anemometer, 4-20mA Output, 60 m/s	4716, 4717, 8797, 9234, 9319	Any cable may be used; if present, Yellow (Out 2) is not used and may be left disconnected

Installation and Technical Drawings

Mounting Mast Orientation

Refer to the technical drawing for details on mounting mast design. Orient the cross-holes in the top of the mounting mast such that they are lined up parallel to the turbine nacelle centerline.

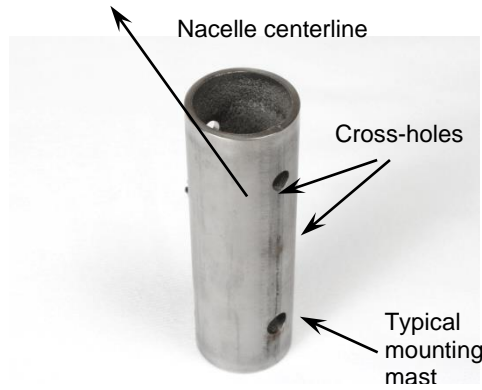

Align cross-holes parallel to nacelle centerline.

Prepare Shield

Based on your decision about the cable shield connection scheme (see previous section and Appendix A), cut off or attach the shield to the mounting mast. If you choose to cut the shield wire, make sure to cut it off short enough to avoid touching the mounting mast or bolt.

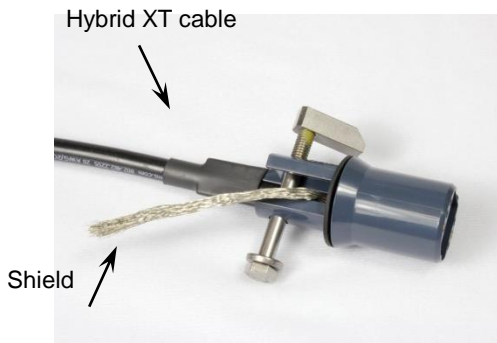

Prepare shield wire.

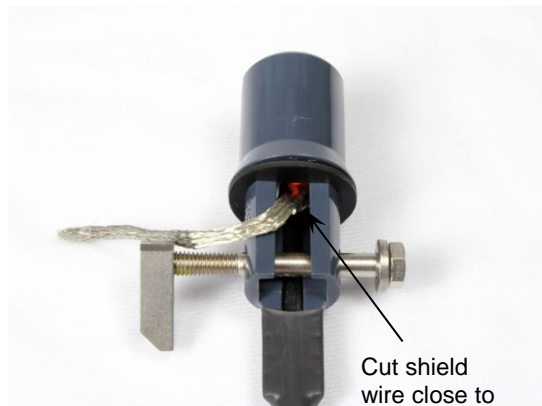

If cutting shield wire, cut close to connector base as shown.

Mount Connector

Remove the nut, washer, and bolt from the connector. Feed the cable through the mounting mast until the connector reaches the mast. Align the bolt hole in the connector with the holes in the mounting mast such that the "TOWARD ROTOR" text molded onto the connector leg is oriented toward the turbine rotor. If you are connecting the shield to the mounting mast, do so now.

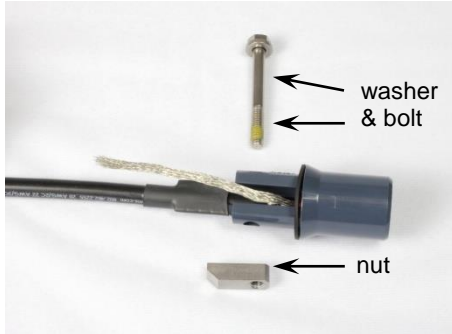

Remove the nut, washer, & bolt.

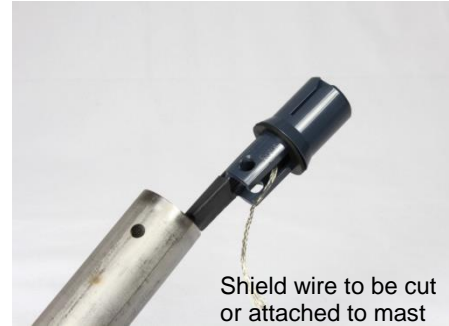

Feed cable through mast.



Install connector with "TOWARD ROTOR" text pointing to the rotor.

Be sure that the connector is snug against the top of the mounting mast and that the washer is on the bolt (compression of the rubber washer may be necessary) then pass the bolt through the mast and connector. Now attach the nut to the bolt a few turns until the nylon patch is in contact with the nut. The nylon patch prevents the nut from backing off the bolt threads. Note that the washer is between the mounting mast and the bolt head.



Secure connector to mast with bolt, washer, and nut.

The Hybrid XT sensors have four ridges running vertically inside the body's lower end as shown in the picture below. These ensure that the sensor mounts securely on the mounting mast.

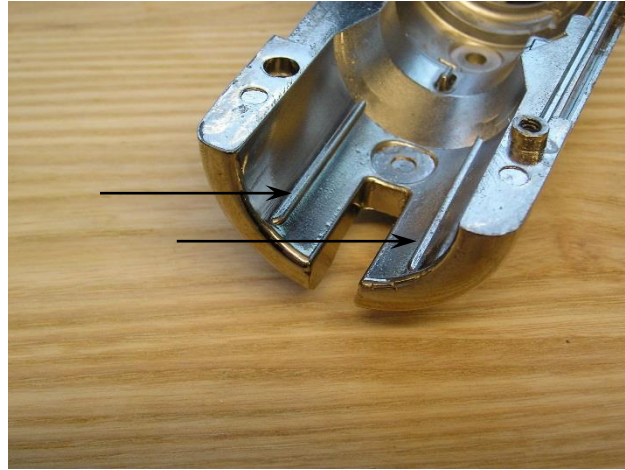

If attaching the shield to the ground screw, make sure that it does not interfere with the mounting ridges by running it straight down the mast from the connector to the ground screw. Do not wrap the wire around the mast. The picture below shows the ground screw attachment option.



Suggested method for attaching shield to mast.

Connect Cable to Controller

Route the sensor cable into the nacelle and to its connection point. It may be helpful to label the end of each wire before pulling the cable to its connection point. Following the color code, connect the sensor wires and shield wire to the turbine controller and heater power supply.

Sensor Common	Black, 22 AWG
Sensor Power	Red, 22 AWG
Sensor Signal	White, 22 AWG
N/A – not used	Yellow, 22 AWG (on all cables shipped since January, 2016)
Heater – *	Orange/White, 20 AWG
Heater + *	Orange/Black, 20 AWG

NOTICE

****When powering the sensor heater with DC power, Orange/White needs to be connected to DC Ground (-) and Orange/Black to DC Power (+). The using AC power the wiring order does not matter.***

Mount Sensor

To attach the sensor to the mounting mast, slide the clamp bolt and washer away from the mounting mast until the nut is against the mounting mast and is hanging vertically. Rotate the Hybrid XT sensor body so that the “THIS SIDE TOWARD ROTOR” label is facing the turbine rotor. This aligns the internal key with the alignment slot in the connector. Now, slide the sensor down over the boom carefully making sure that the key drops into the slot. Continue to slide the sensor down until it is firmly seated on the nut. There will be some drag as the o-ring seal and the connector pins engage. Tighten the bolt using a 10 mm wrench to 7 N-m (5 ft-lbs). Replacement washers, nuts and bolts can be ordered from Renewable NRG Systems (part #4422).

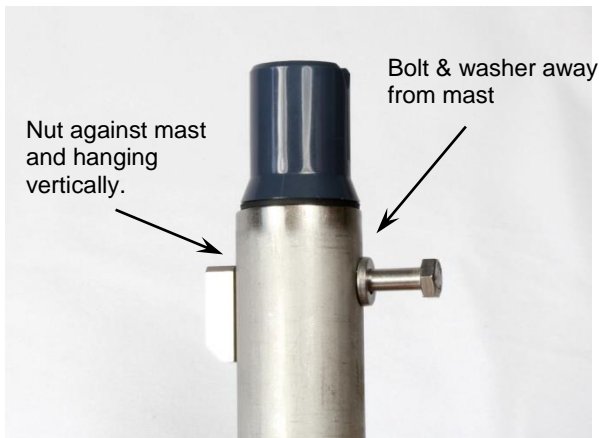

Slide sensor down over mast.

Technical Drawing

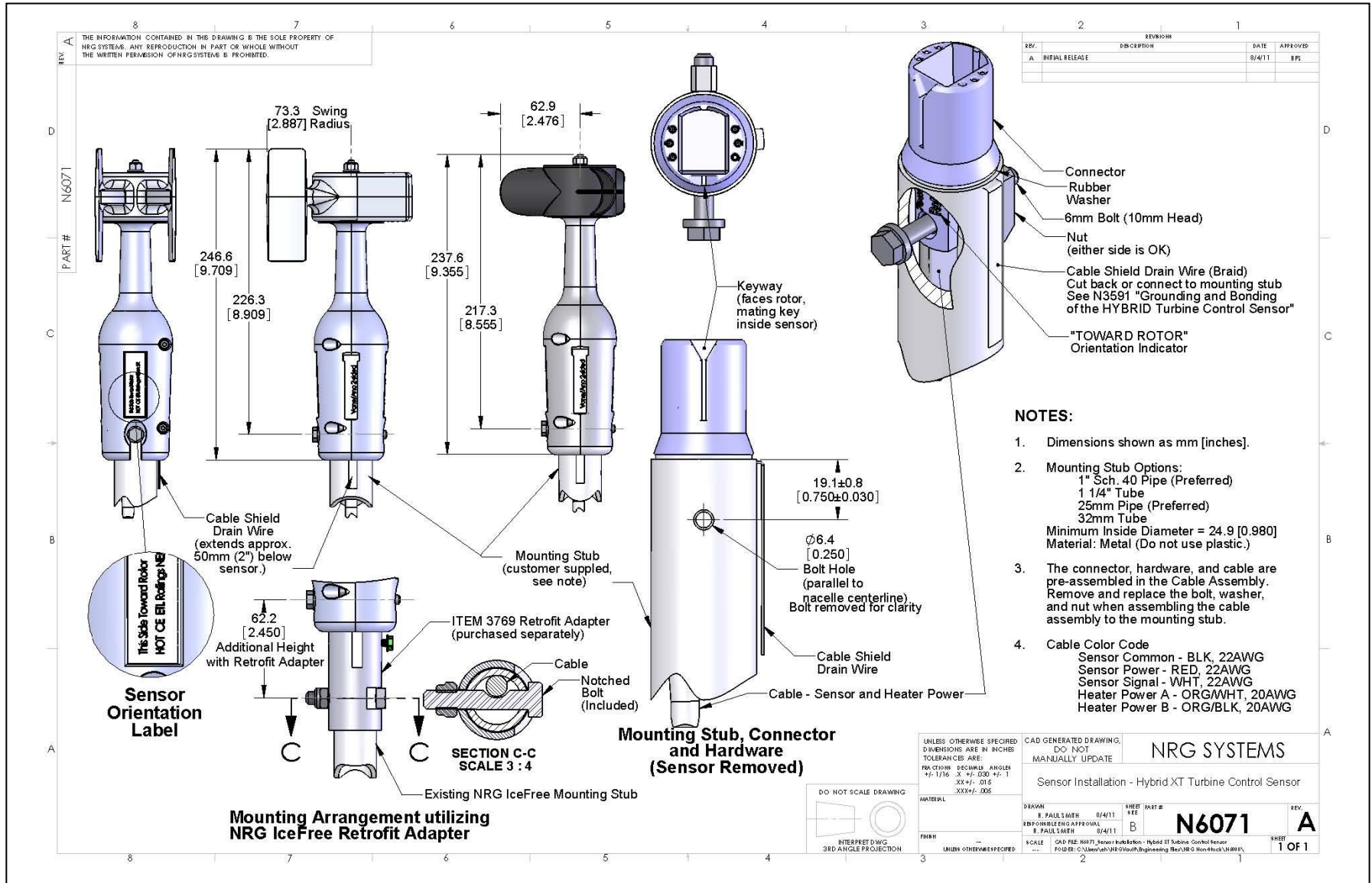

Note: See specifications for more details

Grounding and Bonding Hybrid XT™ sensors for over-voltage protection

Introduction

The purpose of this document is to outline Renewable NRG Systems' recommended practices for wiring, grounding, and bonding of Hybrid XT™ turbine control sensors. The goal is to provide the best possible protection against direct and indirect lightning damage for both the sensor and the interconnected turbine systems.

This document also details the internal construction of the sensor's bonding and over-voltage protection. This allows the wind turbine designer to coordinate the sensor grounding and Over Voltage Protection (OVP) with the rest of the turbine's Lightning Protection System (LPS).

Recommended Practices

The long-term reliability and the Electromagnetic Compatibility (EMC) performance of the sensor are dependent on proper installation and connections. These recommendations could apply to any control electronics or sensors, but are particularly critical for wind sensors because they are exposed on the top of the nacelle.

1. IEC 61400-24 classifies several Lightning Protection Zones (LPZ). LPZ 0_A is exposed on the surface of the turbine and is subject to direct lightning attachment. The turbine must provide air terminals such as lightning rods to protect the sensors from direct lightning attachment. This creates an area in LPZ 0_B to mount the sensors.
2. Careful routing of the lightning down-conductor and coordination of the grounding and bonding of the down-conductor(s) to the turbine's LPS is required to minimize the energy coupled into other systems such as the sensors. Provide maximum possible spacing between lightning down-conductors and any control cabling or raceway. Do not route any other cabling or raceway alongside the lightning down-conductors. These measures will minimize the coupling of lightning electromagnetic pulse (LEMP) energy into other turbine systems.
3. The Sensor body is metal, and bonds to the sensor mounting mast. The mounting mast must be metal. Take particular care to bond the sensor mounting mast to the turbine's LPS in coordination with the placement and bonding of the lightning air terminals and bonding of the turbine frame and nacelle.
4. Use shielded or "screened" cable with high shield coverage for sensor cabling. We recommend bonding the cable shield to the grounding system at both ends- at the sensor, and at the connection to the turbine control system- to provide maximum protection from LEMP. However, see note 6 about preventing ground loops. Renewable NRG Systems supplied cables provide a shield at the sensor end. If your LPS design does not use this shield drain, trim it off to prevent short circuits.
5. Run the sensor cabling in metallic raceway or conduit. Bond the raceway or conduit to the LPS at both ends. This provides protection for the sensor and cabling against EMI and LEMP.

The purpose of recommendations 1 through 5 is to provide shielding of the internal sensor electronics, heater, and cabling so that they are protected to LPZ 1, per IEC 61400-24.

Recommendations 6 and 7 relate to ground loops and over-voltage protection.

6. Provide sufficient bonding to prevent ground loop currents in the shields and raceways. Whenever possible, it is better to resolve the underlying grounding problems, rather than leaving the shield unconnected to prevent ground loop current flow.
7. Since the sensor's electronics and cabling are in LPZ 1, isolation and or over-voltage protection should be provided at the interface between the sensor cabling and turbine control system to provide LPZ 2 or better protection for the controller.

Sensor Construction Notes

The Hybrid XT™ turbine control sensor's enclosure is metal, which provides an overall EMI shield for the internal components of the sensor. The sensor includes internal over-voltage protection (OVP) components. For these features to be effective, the sensor must be installed and connected properly. Figure 3 shows the internal connection details of the sensor bonding and OVP.

The direction vane is shown as an example; the anemometer uses the same construction.

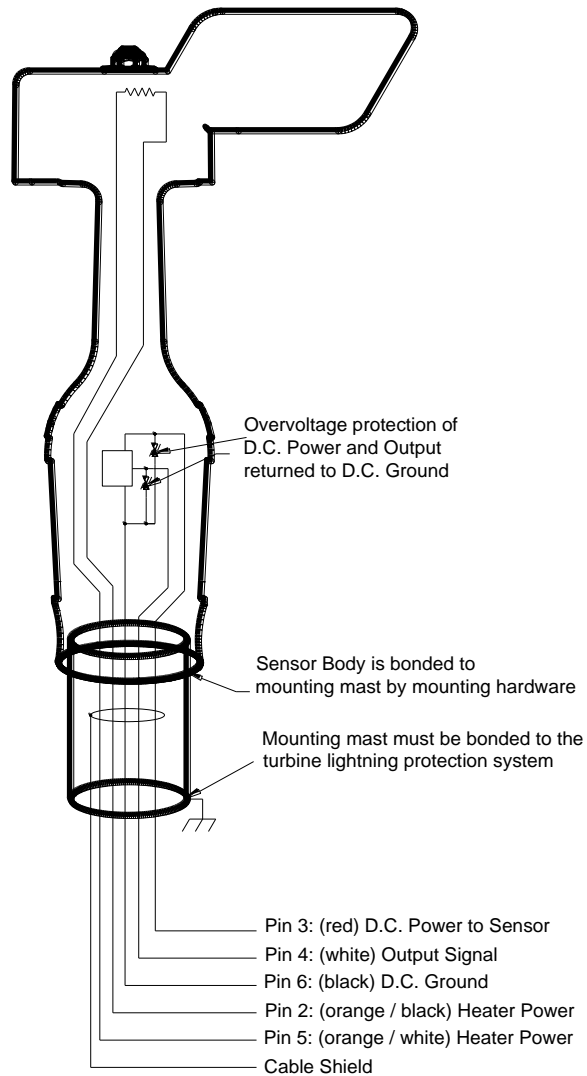

Internal bonding and OVP of the Hybrid XT™ turbine control sensor

NOTICE

**When powering the sensor heater with DC power, Orange/White needs to be connected to DC Ground (-) and Orange/Black to DC Power (+). The using AC power the wiring order does not matter.*

Reference:

1. IEC TR 61400-24: 2002: *Wind Turbine Generator Systems- Part 24: Lightning Protection.*
2. IEC 61312-1: 1995: *Protection against Lightning Electromagnetic Impulse- Part 1: General Principles*

Warranty & Repair

Renewable NRG Systems (RNRG) warrants its products for a period of two years from date of original purchase solely for the benefit of the original consumer purchaser. If this product is determined to be defective in materials or workmanship, RNRG will, at RNRG's option, repair or replace this product without charge. This warranty does not cover damage due to improper installation or use, accident or misuse, damages due to any unauthorized service or lightning. This warranty also will not apply if any seal on any instrument or sensor is broken, if any cable has been severed, or the equipment was not adequately grounded.

NOTICE

Always power the heater on your Hybrid XT sensor! Failure to maintain constant heating may lead to corrosion or inferior sensor performance. Constant heating prevents condensation from forming on the bearings, enabling the sensor to achieve a 10 year service cycle. If the sensor is used without the heater, the warranty will be void

To return a defective product, request an RMA (return merchandise authorization) number by calling us at the number below or by emailing support@renewablenrgsystems.com, or by submitting a request through our website's Technical Support area.

Please provide the serial number of the item as well as date of purchase. No products will be accepted for warranty work without an RMA number. The product must be returned, postage prepaid, to RNRG with a brief description of the problem, RMA number and a return address with phone number.

The foregoing limited warranty is given in lieu of all other warranties, express or implied. RNRG specifically disclaims all implied warranties including, but not limited to, any implied warranties of merchantability and fitness for a particular purpose.

The above limited warranty expressly excludes, and RNRG shall not be liable for, any incidental or consequential damages caused by or related to the selection, use of, inability to use or malfunction of this product.

RNRG will make a good faith effort to repair or replace promptly any product which proves to be defective within the warranty period. First, contact RNRG or the representative from whom the product was purchased and ask for an RMA number. Inspect your shipments for damage to packages or missing packages immediately upon receipt. Record any such exceptions on the freight receipt of the delivery agent. If any contents are damaged or missing, report this in writing to the freight carrier and send RNRG a copy of the damage report. If you insured the shipment yourself, report any damages to your insurance carrier.

Tel: 802-482-2255

Fax: 802-482-2272

email: support@renewablenrgsystems.com

website: <https://www.renewablenrgsystems.com/technical-support>

Sending Items for Repair

INTERNATIONAL CUSTOMERS

Contact Renewable NRG Systems by phone, email, or through our website to obtain an RMA number (Return Material Authorization). Write the RMA number clearly on all shipping cartons.

Tel: 802-482-2255

Fax: 802-482-2272

email: support@renewablenrgsystems.com

website: <https://www.renewablenrgsystems.com/technical-support>

2. Send your item to Renewable NRG Systems "Delivery Duty Paid" (see address below) using a door-to-door courier service such as UPS, FedEx, or DHL. If the repair is not urgent, please send your package by Airmail. (Courier services deliver the package directly to us, customs cleared.)

Renewable NRG Systems will not accept packages shipped Freight Collect or with Collect charges.

If Renewable NRG Systems refuses the shipment, the courier service will charge your account return freight charges.

DO NOT send return items by direct or consolidated air freight service with an airline.

The cost for air freight may seem lower than the courier service, but air freight costs do not include customs clearance, airport handling, break bulk fees, and inland delivery to Renewable NRG Systems.

3. Attach a Commercial Invoice to the carton. The Commercial Invoice should include the following information:

- Name and address of the shipper.
- Renewable NRG Systems' complete address and telephone number as the consignee.
- Description of the items being returned.
- Quantity of each item being returned.
- Value for customs / insurance (purchase price or replacement cost).
- Number of cartons with respective weights and dimensions.
- Please include the following statement to avoid paying US import duties:

"These items are being returned to their U.S. manufacturer. Country of manufacture and origin is USA, HTS CODE 9801.00.1012."

4. Pack your repair item in a sturdy packing carton. Tag each item with a brief description of the problem.

5. Insure your shipment against damage or loss in transit. Be sure to check the appropriate box and enter a "Value for Carriage" (insurance) on your air waybill. The value is the purchase price of the equipment or what it would cost to replace the equipment if the shipment were lost. Keep a record of the tracking number.

Once your item arrives, we will assess the item and notify you of the repair cost. Any repair charges and freight costs, if applicable, are payable before Renewable NRG Systems will return the repaired item to you via door-to-door courier service. Renewable NRG Systems will send you a shipment advisement when the repaired item is shipped.

International Customers:

Before sending the repair item to Renewable NRG Systems, check with your local customs authorities about provisions in your country for exporting and re-importing repair items. Some countries treat repair shipments like new shipments and charge import duties and taxes again upon re-importation. Other countries have specific steps to follow or specific forms to complete which help reduce the import duties upon re-import of the item.

US CUSTOMERS

Please see items 1, 4, and 5 above. Send your item(s) to Renewable NRG Systems "Freight Prepaid and Insured." **Shipments sent freight collect will not be accepted by Renewable NRG Systems.**

Renewable NRG Systems
Attn: RMA- _____
110 Riggs Road
Hinesburg VT 05461 USA

Declaration of Conformity

(in accordance with ISO/IEC 17050-1:2004)



NRG Systems Document Number: 7737, Rev D

SUPPLIER: NRG SYSTEMS
SUPPLIER ADDRESS: 110 Riggs Road, Hinesburg, VT 05461, USA
Telephone: 802 482 2255, Fax: 802 482 2272
Email: sales@nrgsystems.com

DECLARES THAT THE PRODUCTS: ICEFREE HYBRID™ XT TURBINE CONTROL SENSORS, INCLUDING:

IceFree Hybrid™ XT Anemometer	Item 4718
IceFree Hybrid™ XT Vane	Item 4715
IceFree Hybrid™ XT 4-20 mA Anemometer 50 m/s	Item 5763
IceFree Hybrid™ XT 4-20 mA Vane CW	Item 5762
IceFree Hybrid™ XT Push/Pull Output Anemometer	Item 7901
IceFree Hybrid™ XT Push/Pull Active Low Vane	Item 7894
IceFree Hybrid™ XT 4-20 mA Anemometer 60 m/s	Item 9365
IceFree Hybrid™ XT 4-20 mA Vane Counter-CW	Item 9362
IceFree Hybrid™ XT Push/Pull Active High Vane	Item 9363

ARE IN CONFORMITY WITH THE REQUIREMENTS OF THE FOLLOWING DOCUMENTS:

EN61326-1:2013, Class A "Electrical Equipment for Measurement, Control, and Laboratory Use—EMC Requirements", in accordance with: **CISPR 11; EN 55011:2009; EN 61000-4-2; EN 61000-4-3; EN 61000-4-4; 61000-4-6; EN 61000-4-8; 61000-4-20;**

IEC 61010-1:2010 "SAFETY REQUIREMENTS FOR ELECTRICAL EQUIPMENT FOR MEASUREMENT, CONTROL, AND LABORATORY USE"

ADDITIONAL INFORMATION:

These products comply with the requirements of the applicable directives **2006/42/EC, 2004/108/EC, 2002/96/EC,** and standard **EN 61010-1** and therefore, the product is CE marked in accordance with **93/68/EEC.**

FCC compliance is demonstrated with compliant CISPR data.

The design documentation, test reports, and assessment laboratory accreditation are on file with Mr. Barry King, Electrical Engineer.

Issued at Hinesburg, VT, USA

19 November 2016

A handwritten signature in blue ink, appearing to read "Wallace Lafferty", written over a horizontal line.

Wallace Lafferty
VP Engineering

Appendix A: FG# 4718 – Hybrid Turbine Control Anemometer

Output Circuit Operation

The Hybrid XT anemometer provides a square wave output signal with a frequency proportional to the head rotation rate (wind speed). The square wave amplitude is determined by the power supply voltage.

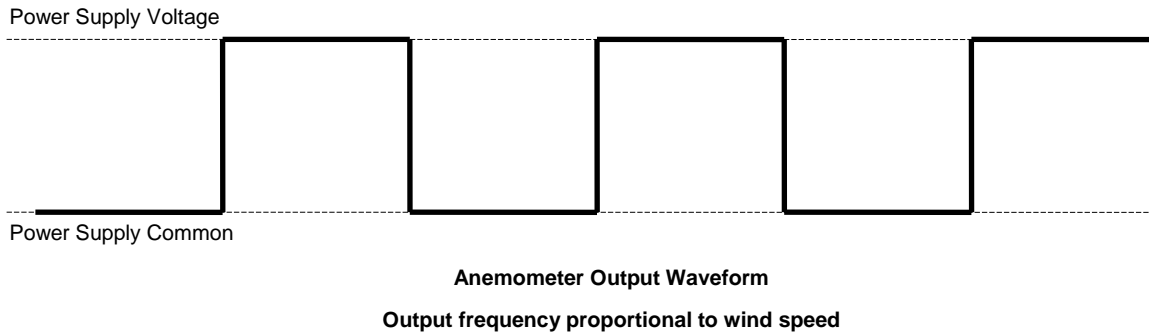

Under normal operation, the frequency varies from 1 Hz to 141 Hz or higher. When the head is not rotating, the frequency output is 1 Hz to indicate the sensor is still functioning properly. If the frequency output is 0 Hz, this indicates a fault condition. The most likely causes would be: no power, wiring problem, or a failed sensor.

The anemometer output signal can be timed on either the rising or the falling edges. For best accuracy, time and count many cycles then divide the count by the time for an average frequency. This technique also effectively filters out short-term wind speed variations.

Appendix B: FG# 5763 – 4-20 mA, 50 m/s Anemometer

Output Circuit Operation

The Hybrid XT 4-20 mA Turbine Control Anemometer provides an industry standard 4 to 20 mA output signal sourced by the sensor. The output range of 4 to 20 mA corresponds to wind speeds of 0 to 50 m/s.

Under normal operation, the output signal current varies from 4 to 20 mA. A signal outside this range indicates a fault condition. The most likely causes would be a loss of power, a wiring problem, or a failed sensor.

The Hybrid 4-20 mA signal output has been engineered to adapt to most common 4-20 mA current loop inputs. The range of compatible loads for the current loop signal does depend on the power supply voltage provided to the sensor. At the lowest specified power supply voltage of 11 V DC, the output loop load (or “burden”) may be 350 Ohms maximum (a 7 volt maximum voltage drop). When provided with its maximum 24 V DC power supply voltage, the sensor can drive up to a 1000 Ohm loop load (a 20 V maximum voltage drop).

Appendix C: FG# 7901 – Push-Pull Anemometer

Output Circuit Operation

The Hybrid XT anemometer provides a square wave output signal with a frequency proportional to the head rotation rate (wind speed). The square wave amplitude is determined by the power supply voltage.

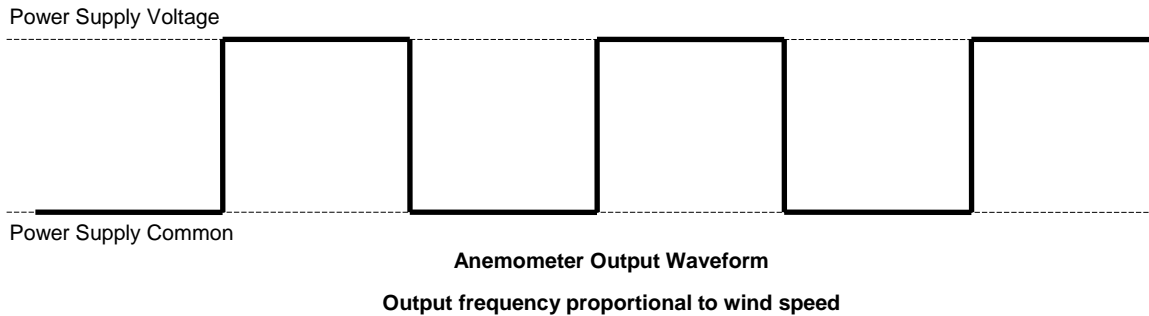

Under normal operation, the frequency varies from 0 Hz to 141 Hz or higher. The anemometer output signal can be timed on either the rising or the falling edges. For best accuracy, time and count many cycles then divide the count by the time for an average frequency. This technique also effectively filters out short-term wind speed variations.

Appendix D: FG# 9365 – 4-20mA, 60 m/s Anemometer

Output Circuit Operation

The Hybrid XT 4-20 mA Turbine Control Anemometer provides an industry standard 4 to 20 mA output signal sourced by the sensor. The output range of 4 to 20 mA corresponds to wind speeds of 0 to 60 m/s.

Under normal operation, the output signal current varies from 4 to 20 mA. A signal outside this range indicates a fault condition. The most likely causes would be a loss of power, a wiring problem, or a failed sensor.

The Hybrid 4-20 mA signal output has been engineered to adapt to most common 4-20 mA current loop inputs. The range of compatible loads for the current loop signal does depend on the power supply voltage provided to the sensor. At the lowest specified power supply voltage of 11 V DC, the output loop load (or "burden") may be 350 Ohms maximum (a 7 volt maximum voltage drop). When provided with its maximum 24 V DC power supply voltage, the sensor can drive up to a 1000 Ohm loop load (a 20 V maximum voltage drop).