

Pyranometer Hukseflux SR 11

Order-No: P 7351

- "First Class" solar radiation sensors
- Compliant with WMO and ISO standards
- Easy installation and maintenance
- Two glass domes
- Utilises thermopile sensor
- Connectable to established data loggers
- Applications:
 - Scientific grade meteorological observations
 - Climate - & solar collector testing
 - Outdoor solar radiation measurements
 - Building physics



Description:

SR11 is a solar radiation sensor that can be applied in scientific grade solar radiation observations. It complies with the "first class" specifications within the latest ISO and WMO standards. The scientific name of this instrument is pyranometer.

SR11 serves to measure the solar radiation flux that is incident on a plane surface in W/m^2 from a 180 degrees field of view (also called "global" solar radiation). Working completely passive, using a thermopile sensor, SR11 generates a small output voltage proportional to this flux. Employing two glass domes, certain measurement errors are reduced; in particular thermal offsets, so that a high measurement accuracy can be attained.

Using SR11 is easy. For readout one only needs an accurate voltmeter that works in the millivolt range. To calculate the radiation level the voltage must be divided by the sensitivity; a constant that is supplied with each individual instrument.

Connection:

SR11 can be directly connected to most commonly used datalogging systems.

Applications:

SR11 can be used for scientific meteorological observations, building physics, climate- and solar collector testing. A common application is for outdoor solar radiation measurements as part of a meteorological station. This application requires horizontal levelling; levelling feet (7) and a level (11) are included. The SR11 cable can easily be installed or replaced by the user.

Compliant with WMO and ISO Standards:

Applicable standards are ISO 9060 and 9847, WMO (World Meteorological Organisation), and ASTM E824-94. SR11 can also be used for stability estimations according to EPA (EPA- 454/R-99-005). See also model LP02 for lower accuracy measurements.

Specification Pyranometer Hukseflux SR 11 - P 7351:

ISO classification	First Class
Spectral range	305 to 2800 nm
Sensitivity (nominal)	15 $\mu\text{V} / \text{W}/\text{m}^2$
Temperature range	-40 to +80°C
Range	0 to 2000 W/m^2
Temperature dependence	< 0.1%/°C
Calibration traceability	WRR
Manufacturer	Hukseflux Thermal Sensors B.V.

Options:

- Additional cable length x meters (add to 5m)
- AC 100 / AC 420 amplifiers
- With LI 19 hand held readout

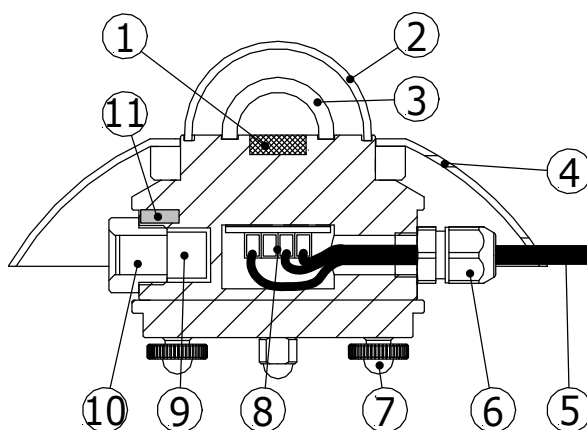

Figure 1 SR11 solar radiation sensor. (1) sensor, (2, 3) glass domes, (5) cable, standard length 5 m, (9) desiccant.

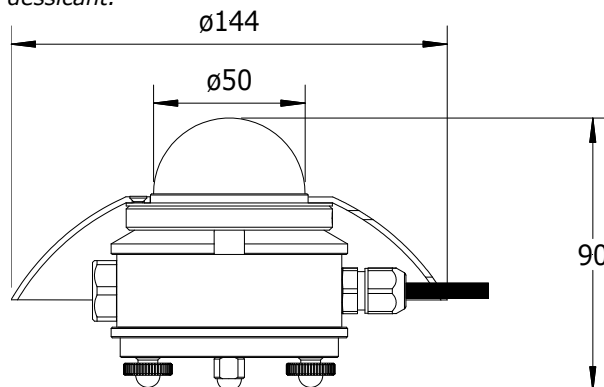

Figure 2 SR11 dimensions in mm. Standard cable length is 5 m. Cable can be installed / replaced by the user.